

HEADLIGHT BRACKET OVERVIEW

<p>470H</p>  <p>Metal, long, black, L = 50 mm</p>	<p>471F</p>  <p>Metal, short, black</p>	<p>471U</p>  <p>Diecast zinc, U shaped, black</p>	<p>474D</p>  <p>Stainless steel, shiny, short, L/S = 25/18 mm</p>
<p>474DS</p>  <p>Stainless steel, black, short, L/A = 25/18 mm</p>	<p>475D</p>  <p>Stainless steel, shiny, medium length, L/A = 45/18 mm</p>	<p>475D/1</p>  <p>Stainless steel, shiny, medium length, L/A = 45/25 mm</p>	<p>475DS</p>  <p>Stainless steel, black, medium length, L/A = 45/18 mm</p>
<p>475DS/1</p>  <p>Stainless steel, black, medium length, L/A = 45/25 mm</p>	<p>474DL</p>  <p>Stainless steel, shiny, long, L/A = 60/18 mm</p>	<p>474DLS</p>  <p>Stainless steel, black, long, L/A = 60/18 mm</p>	<p>4706CB</p>  <p>Chromed metal bracket, for head tube mounting (1")</p>
<p>471B</p>  <p>Plastic, for head tube mounting (1")</p>	<p>471B/1</p>  <p>Plastic, for head tube mounting (1 1/8")</p>	<p>471LH</p>  <p>Plastic, long, extremely break proof, L = 75 mm</p>	<p>471AR</p>  <p>Adaptor for RST forks</p>
<p>471A</p>  <p>Adaptor for SR suspension forks CR8, NEX</p>	<p>471E</p>  <p>Extension piece (in addition to 471A for hydraulic brakes)</p>	<p>471AXK</p>  <p>Adaptor, short, for SR suspension forks CR9 + NCX from 2009</p>	<p>471AX</p>  <p>Adaptor, long, for SR suspension forks CR9 + NCX from 2009</p>

475K



Cable guide for 475D, 475DS, 475D/1, 475DS/1

475ISS/ISM



Special screw, for all stainless steel brackets

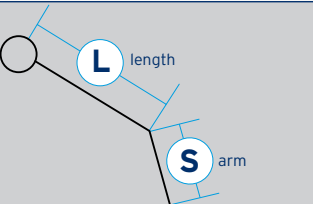

	Basic 170	Oval 171	Lyt 178	Fly 174	Cyo 175Q/R	Retro 1706C
470H	•		•		•	• (chromed)
471F		•		•		
471U		•				
474D		•				
474DS		•				
475D	•		•	•	•	
475D/1	•		•	•	•	
475DS	•		•	•	•	
475DS/1	•		•	•	•	
474DL	•		•		•	
474DLS	•		•		•	
4706CB						•
471B		•				
471B/1		•				
471LH	•	•	•		•	
471AR	•	•	•	•	•	
471A	•	•	•	•	•	
471E	•		•		•	
471AXK		•		•		
471AX	•		•		•	

Only common applications are shown. Further combinations are possible and available upon request.

Reflectors

Cyclists and pedestrians are very much endangered because they are the 'weakest' road users and will often be seen very late by other traffic participants. Reflectors are a considerable safety factor! We only use high quality prisms in order to get high reflection values from small surface areas.

 <p>FRONT 313/5WB¹⁾ Preassembled plastic screw clamp Ø 13-40 mm. Wide angle reflection. Certification marks B, D, E, GB. Also available in red: HECK Type 313/1WB.</p>	 <p>FRONT 313/5U¹⁾ Integral U shaped plastic bracket. Especially suited for cantilever brakes. Weighs only 12 g. Certification marks D, E, GB. Also available in red: HECK Type 313/1U.</p>	 <p>HECK 312H²⁾ Admitted for contour parallel attachment to mudguards (up to 30° inclination). Certification marks D, E. Type 312H/8: with metal strap for riveted attachment.</p>	 <p>HECK MINI-Z 313/1ZB¹⁾ Plastic screw on clamp Ø 13-40 mm. Superior reflection values in spite of small size. Certification marks D (including Z), E.</p>	 <p>Spoke reflector 309 Undetachable. Fits any tyre size. With rotatable plastic brackets. 97 mm long. Easy assembly: just twist into spokes. Certification marks D, E.</p>
 <p>FRONT 313/5WF¹⁾ Metal bracket. Especially suited for suspension forks, V brakes, hydraulic and drum brakes. Wide angle reflection. Certification marks B, D, E, GB. Also available in red: HECK Type 313/1WF.</p>	 <p>FRONT 313/5WU¹⁾ U shaped metal bracket. M6 thread. Especially suited for cantilever brakes. Wide angle reflection. Certification marks B, D, E, GB. Also available in red: HECK Type 313/1WU.</p>	 <p>HECK 313/1²⁾ For screw on attachment to mudguard. Certification marks D, E.</p>	 <p>HECK BIG 316WZ For luggage carrier attachment. Screw connection at 50 mm and 80 mm distance. Complete with 2 screws. Certification mark D (including Z). Type 316: with flat reflector.</p>	 <p>Spoke reflector 309V Design as 309, but complete with twisted plastic fastening elements for narrow spoke clearance.</p>
 <p>FRONT 302F¹⁾ Fastening strap for handlebar annex screw or calliper brake. Standing or suspended assembly. Wide angle reflection. Certification marks B, D, E, GB.</p>	 <p>FRONT 305K¹⁾ Fastening clamp for handlebar shaft. Transverse or upright assembly. Certification marks D, E.</p>	 <p>HECK 314/1²⁾ For mudguard attachment. Especially suited for short type mudguards. Complete with screw. Certification marks D, E. Type 314/8: with metal strap for riveted attachment.</p>	 <p>HECK 313/3Z Format 27 x 91 mm. Carrier mounting. Screw hole distance 50 mm. With 2 screws. Certification mark D (incl. Z).</p>	 <p>Spoke reflector 309M Undetachable. Fits any tyre size. With stainless steel clamps. 85 mm long. Easy assembly: just twist into spokes. Certification marks D, E.</p>
 <p>TEDDY REFLEX 621STPB / CLIP 625 For pedestrians. Clear or coloured reflector.</p>	 <p>FRONT UNIVERSAL 313/5K¹⁾ Tensioning strap and rubber lining for any tube diameter. 10 g only. Certification marks D, E, GB. Also available in red: HECK universal Type 313/1K.</p>	 <p>Spacer 317 With white (forward reflection) and red (backward reflection) reflector, including brackets and assembly instructions. Approved for use within the area of application of the German StVZO.</p>	 <p>SPECIAL 563 Format 36 mm x 61 mm. Self adhesive foil on the back. Certification marks E, SAE. Type 563/2: yellow reflector, Type 563/5: white reflector.</p>	 <p>Spoke reflector 308 113 mm long, wide angle design. Easy assembly: Just twist into spokes. Certification marks B, E, F, GB.</p>

¹⁾ We supply a wide range of fastening straps. For our overall scope of supplies visit www.bumm.de

²⁾ Approved by German StVZO as the required second reflector in combination with the luggage carrier rear light with Z reflector.

SPARE PARTS / TOOLS / ACCESSORIES

Original spare parts, tools and accessories supplied by the specialist manufacturer make cycling and assembly much easier - if only because all components are carefully produced to conform to superior quality standards.

 <p>Headlamp brackets</p>	 <p>Rear light guard, Type 245S</p>	 <p>Spare parts</p>	 <p>Bulbs</p>
 <p>Assembly and cable sets</p>	 <p>Plugs/clips/heat shrink tubes</p>	 <p>Bicycle tools</p>	 <p>Tyre levers, Type 289</p>
 <p>Nipple keys</p>	 <p>Stabilisers, Type 851K</p>	 <p>Chain guards</p>	 <p>Replacement parts for mirrors</p>

For our overall range of spares, tools and accessories visit www.bumm.de

REAR VIEW MIRRORS

Millions of motor bikes and scooters of all brands (BMW, HONDA, KTM, MBK, Peugeot etc.) are equipped with our mirrors. We have applied this high tech standard also to bicycles - our mirrors are absolutely top class! No compromise!

The CYCLE STAR series

Top design mirror, black. Plastic housing: Ø 60 mm, glass, convex lens, large field of vision, with shatter protection. Aluminium stem and adapter.

Complete with standard bracket including bracket and handlebar end fitting, highly adjustable, tilting mechanism, made from ultra light, high grade plastic.

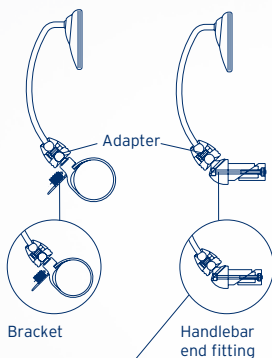

NEW

maximally robust,
made from aluminium



CYCLE STAR 901
Extra long stem



CYCLE STAR 901/1
Short, straight stem



CYCLE STAR 901/2
Only available with handlebar
end fitting



CYCLE STAR 901/3
Short, bent stem



Mirror 902/1
"Eulenspiegel". Plastic housing: Ø 93 mm. Two additional reflectors
for added safety, plane glass. Stem: Ø 6 mm, with metal bracket.



Mirror 902/2
With "biker" symbol, plastic housing: Ø 93 mm, plane glass.
Stem: Ø 6 mm, with metal bracket.